

Drawer S

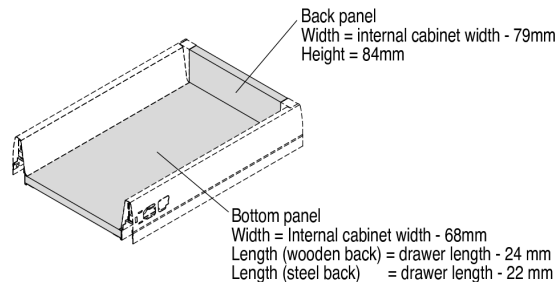

Drawer M

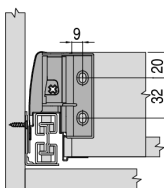
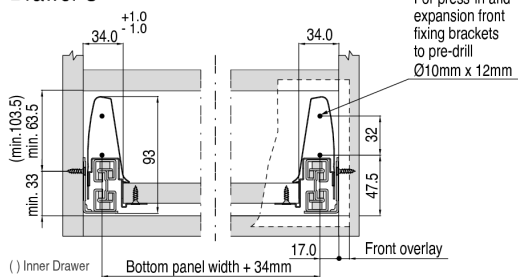
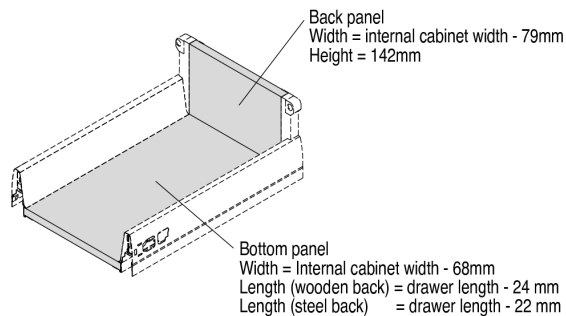
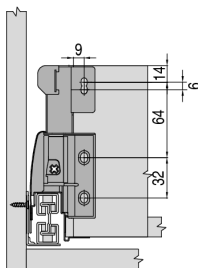
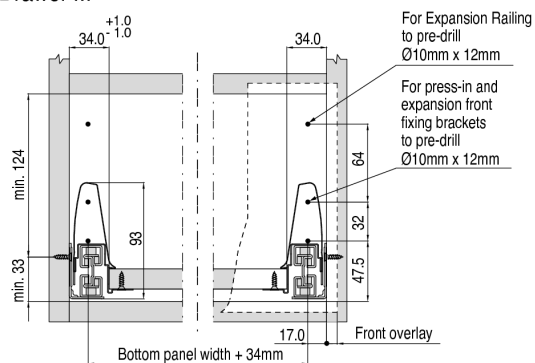

Drawer H

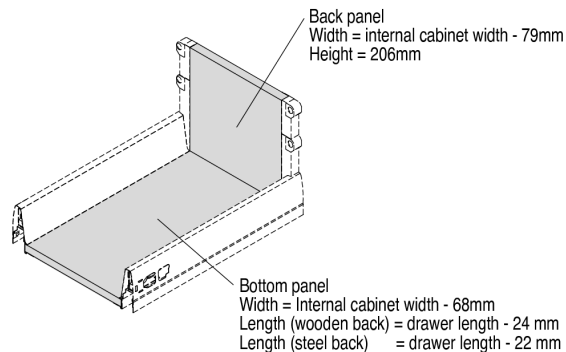
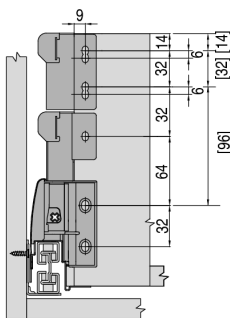
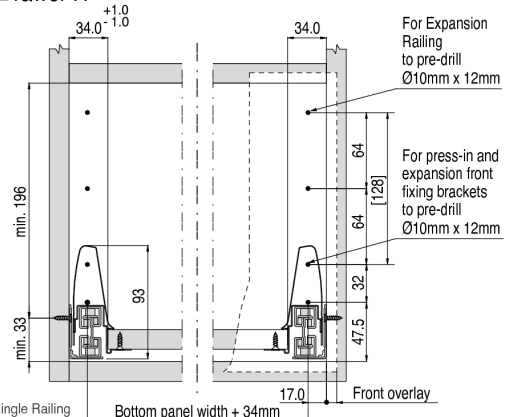

Cabinet Profile Fixing Position

TM46

Standard Drawer

Inner Drawer

Pre-drilling dimensions of bottom panel for fixing Euro screws

Drawer Length

Min. internal cabinet depth = drawer length + 3 mm
Actual loss of extension = 0 mm

Min. internal cabinet depth = drawer length + 12 mm
Actual loss of extension = 9 mm

- 270 mm
- 350 mm
- 400 mm
- 450 mm
- 500 mm
- 550 mm

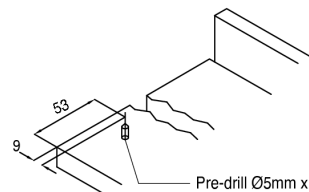
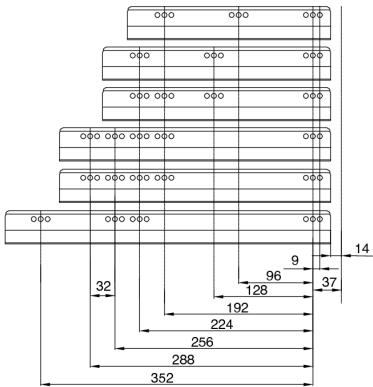
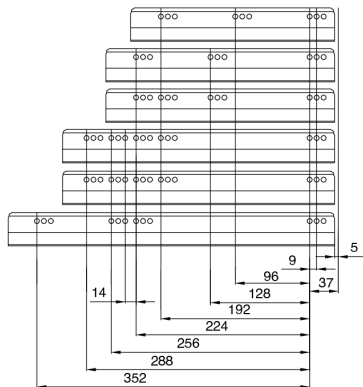

Cutting dimensions for Front panel inner drawer

Cutting dimensions for Cross railing inner drawer

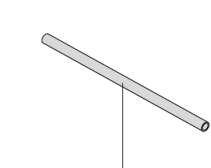
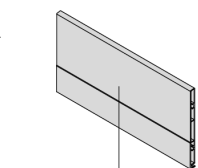

Drawer Assembly

Drawer S Assembly - Wooden Back

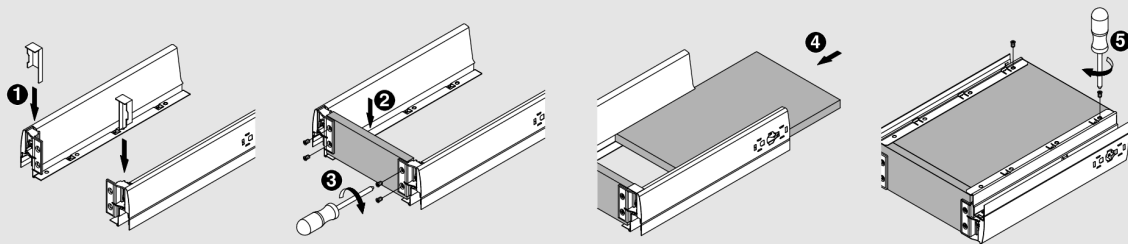

Drawer M, H Assembly - Wooden Back

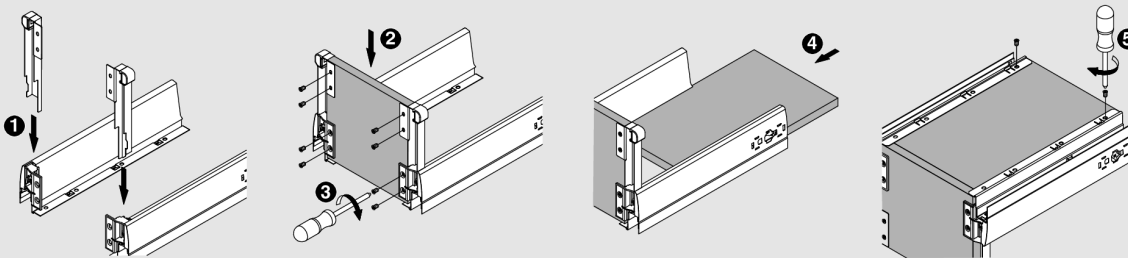

Drawer S, M, H Assembly - Steel Back

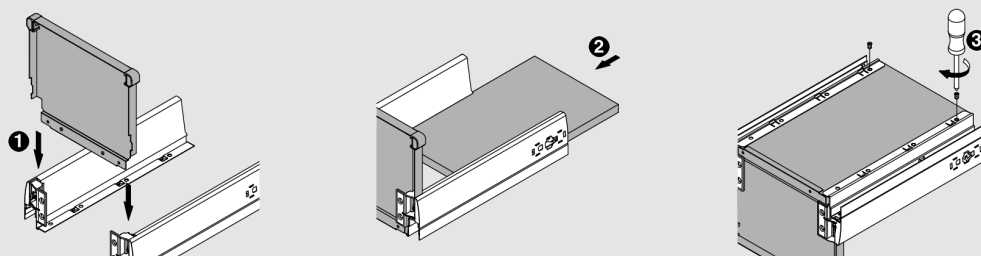

Drawer Front Assembly and Removal

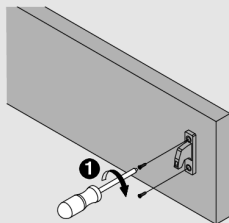

Assembly

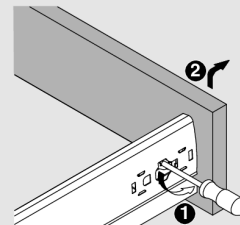
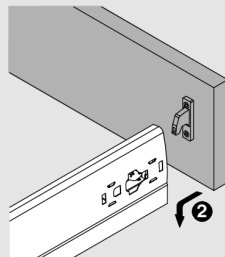

Removal

Drilling Template - RMD.93000.23

Pre-drilling $\text{Ø}5\text{mm} \times 9\text{mm}$
for fixing Euro screws 360.115

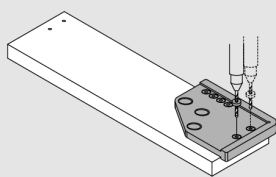

Back panel

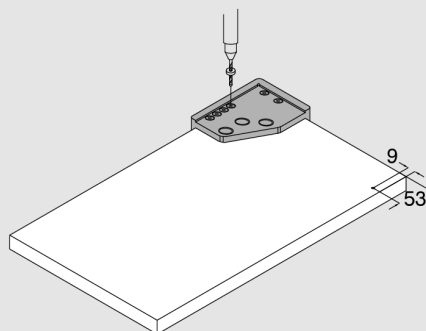

Bottom panel

Aksesori Setia Sdn. Bhd.
Company No. 326521-U

Plot 32, Lengkok Rishah 1,
Kawasan Perindustrian Silibin,
30100 Ipoh, Perak, Malaysia.

Tel : (60) 5 - 527 6055

Fax : (60) 5 - 527 6063

E-mail : info@harn.com

www.harn.com

harn[®]

7001 INST.GB.10.07
Printed in Malaysia Oct 2007

Accessories Assembly

Railing Assembly

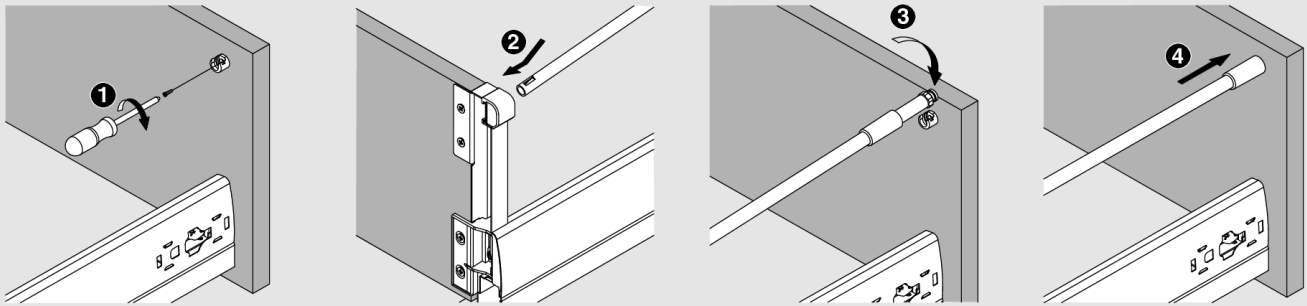

Side Extend Assembly

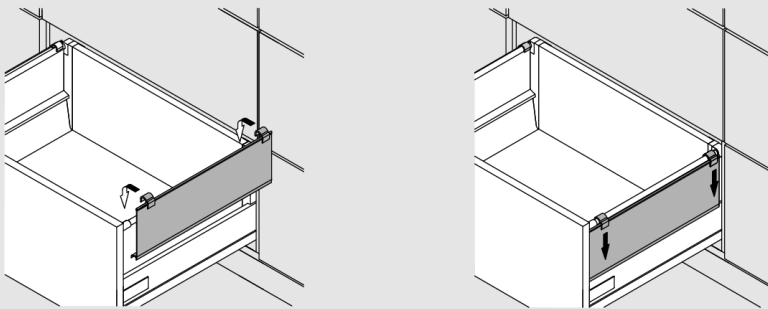

Divider Panel and Lateral Divider Assembly

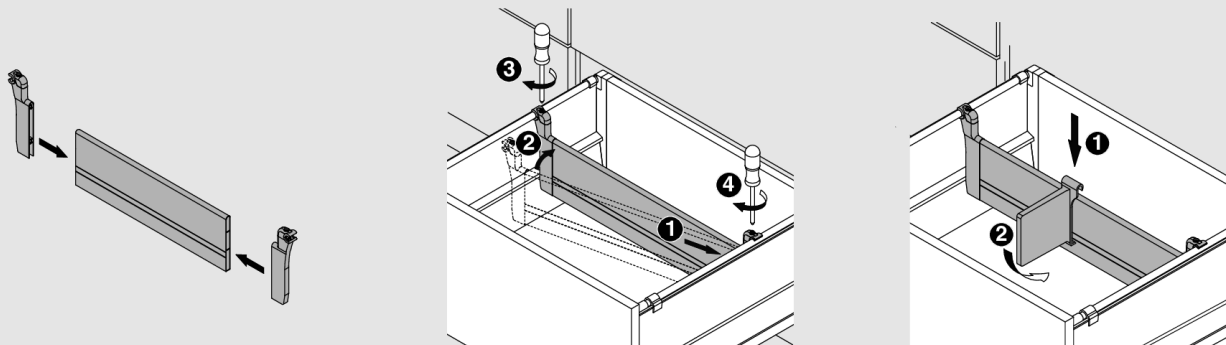

Divider Railing / Filing Cross Hanging Rail Assembly

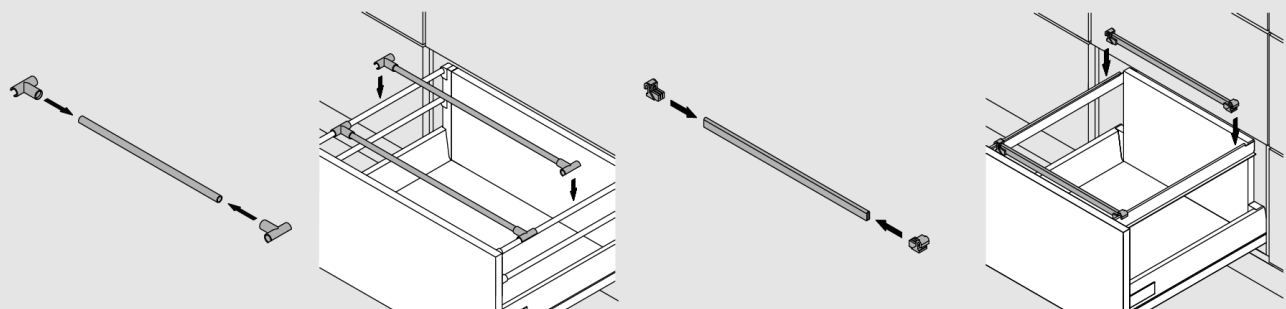

Inner Drawer Assembly

Inner Drawer S Assembly / Removal

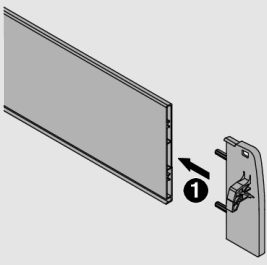

Assembly

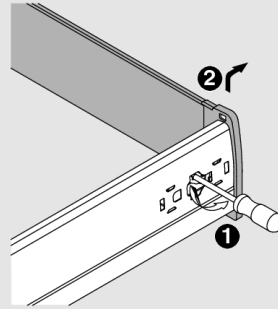
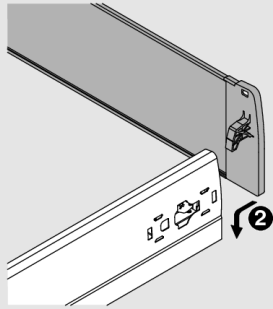

Removal

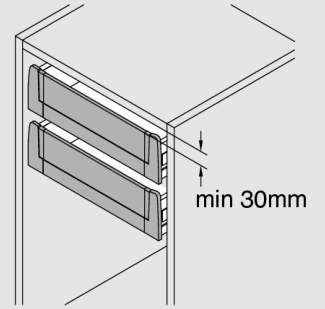

Inner Drawer H Assembly

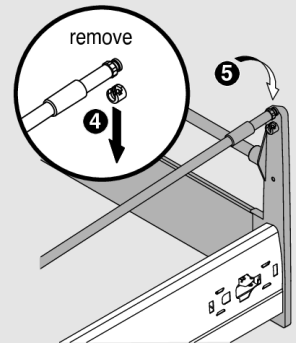
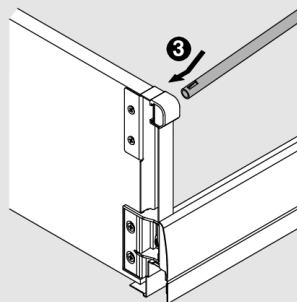
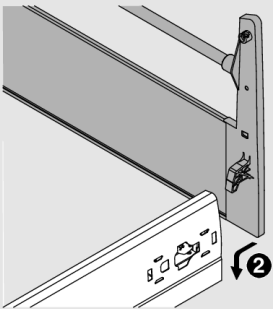
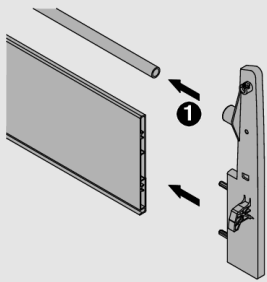

Inner Drawer H Double Railing Assembly

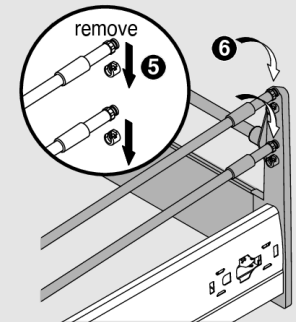
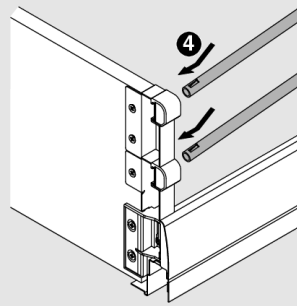
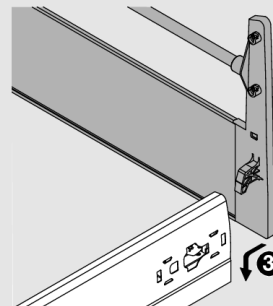
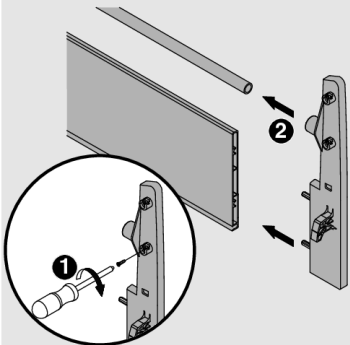

Inner Drawer Locking Piece

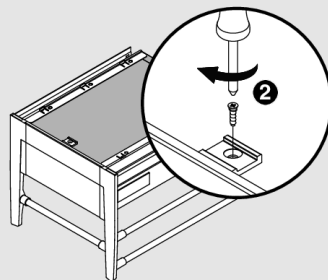
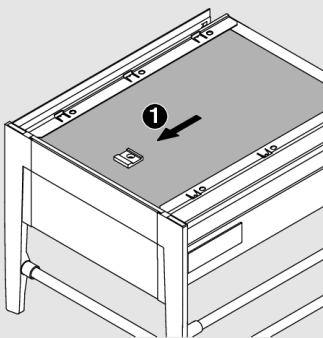

Drawer Front Adjustments

Drawer Front - Side Adjustment

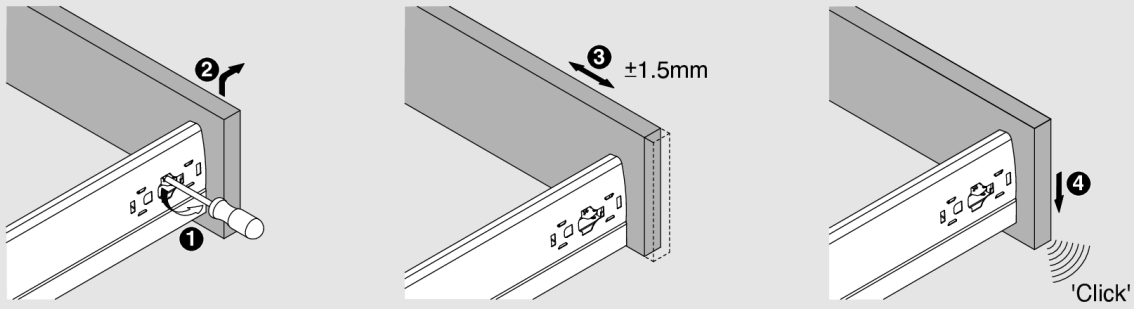

Drawer Front - Height And Tilt Adjustment

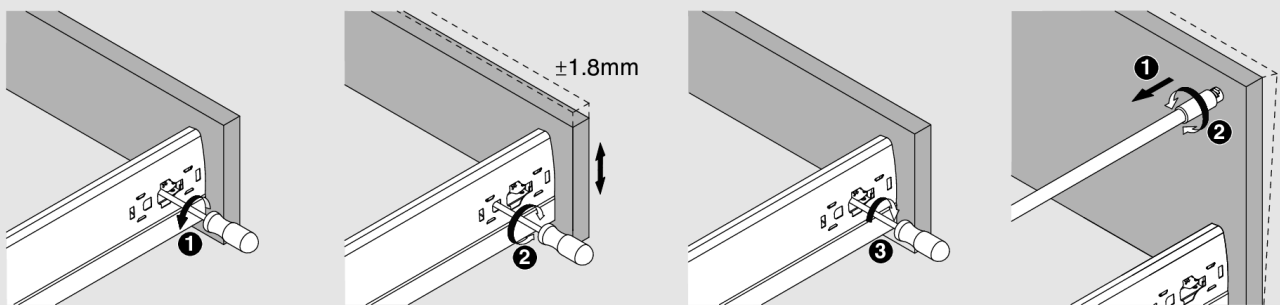

Height Adjustment

Tilt Adjustment

Drawer Insertion And Removal

Drawer Insertion

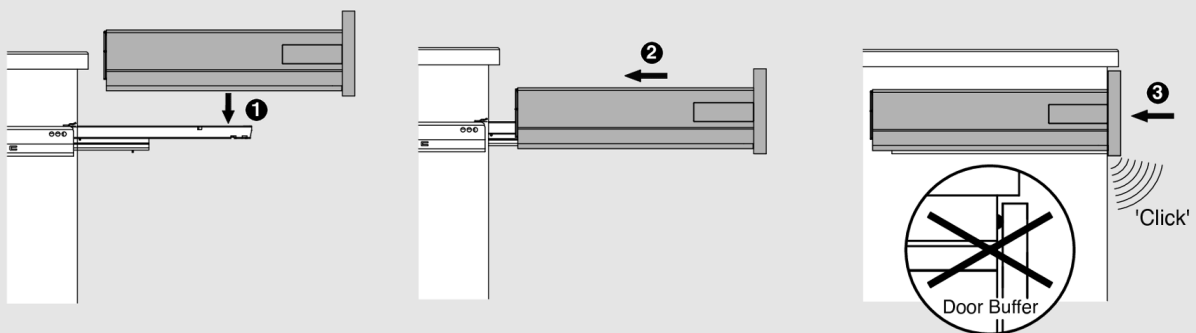

Drawer Removal

